

Fact Sheet

Nova Scotia Power www.nspower.ca has partnered with Irish firm OpenHydro www.openhydro.com to bring a new source of tidal generation to Nova Scotia. The turbine was deployed on November 12th, 2009 in the Bay of Fundy – home to the world's most powerful tides.

Project Milestones

- The in-stream tidal project for the Bay of Fundy was first conceived in 2007.
- Nova Scotia Power was selected as a berth holder in early 2008.
- Design and fabrication of the turbine began in Ireland in 2008 and was completed in August 2009.
- After a competitive process, Cherubini Metal Works was awarded the contract for the turbine's subsea base in April 2009.
- The turbine arrived in Halifax on September 5, 2009.
- After final assembly and commissioning, sea trials took place in the Bedford Basin, located near Halifax Harbour. The turbine moved through the basin at speeds of three knots.
- On November 12th at 12:47 pm the turbine was successfully deployed in the Bay of Fundy.
- Important data will be collected to determine the feasibility of tidal energy. The data will also examine the environmental impact the turbine may have on the Bay of Fundy as well as the impact the Bay of Fundy may have on the turbine.

Tidal Demonstration Site

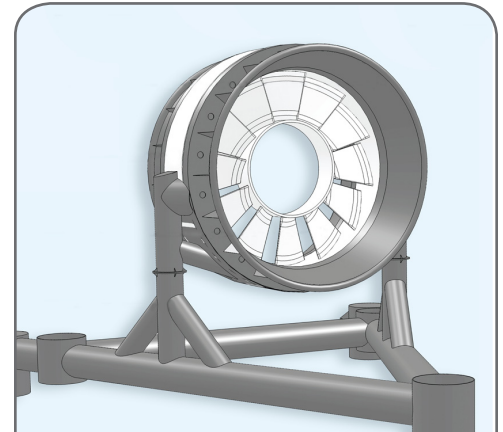
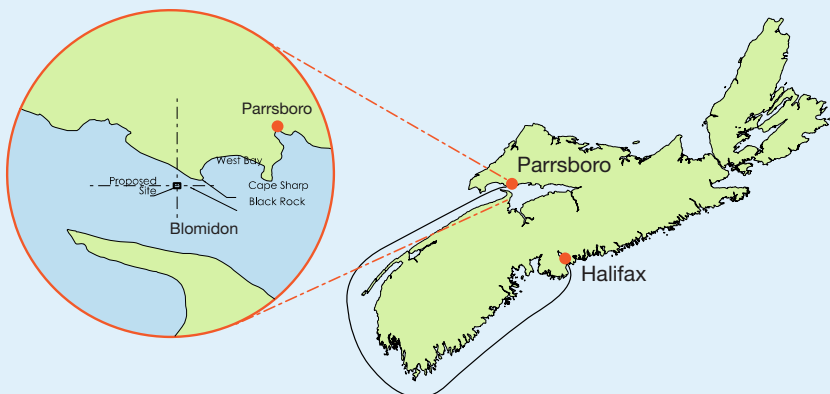

Open-Centre Turbine

- The turbine and subsea base are 16 metres in diameter – that's as high as a six-storey building.
- It is secured by a 400-tonne subsea base. The gravity base was designed by OpenHydro and built by Cherubini.
- In 10 minutes, the turbine was lowered by cables from a purpose-built barge onto the ocean floor.
- Gravity keeps it in place 10-20 meters below the sea surface. Even at low tide, the turbine is not visible above water.
- The blades of the turbine turn in both directions and are able to produce energy during the rise and the fall of the tide.
- The turbine produces one megawatt of energy – enough to power several hundred homes.
- Based on the results of this testing, arrays of Open-Centre Turbines (similar to wind farms) could provide a significant and undetectable supply of clean, predictable, renewable energy in the future.
- Open-Centre Technology is unique



Protecting the environment

- To ensure environmental standards are met the turbine will be tested for one to two years.
- The Open-Centre Turbine has a number of features designed to minimize any impacts on marine life.
- The large open centre is designed to provide a safe passage for marine life.
- The design avoids the use of oils, grease or other lubricating fluids that could be released into the water.
- Tests have also confirmed that the unit produces very low levels of mechanical sound.

Economics

- NS Power will invest \$10 million and receive \$4.6 million in funding from Sustainable Development Technology Canada. Project costs include design and construction of the turbine and subsea base, and deployment.
- As the tidal industry continues to evolve there is great opportunity for further economic spin-offs in Nova Scotia. The Cherubini contract proves that Nova Scotian companies have the capability to be part of the manufacture of this technology in the future.

More information can be found at:

Nova Scotia Power www.nspower.ca/tidal

OpenHydro www.openhydro.com

FORCE www.fundyforce.ca

NS Government www.gov.ns.ca/energy/renewables/public-education/tidal.asp

SDTC www.sdtc.ca

Cherubini www.cherubinigroup.com